

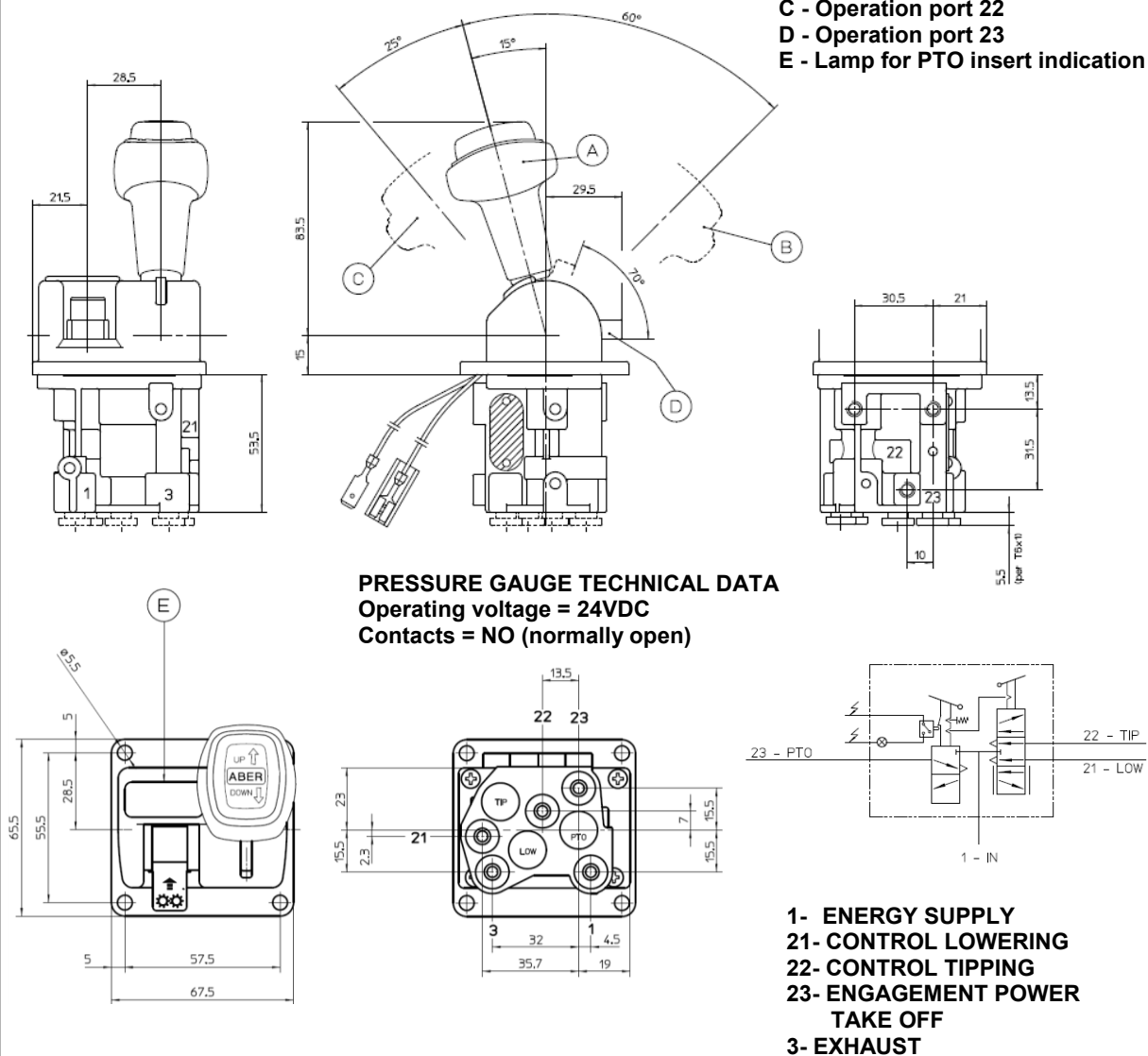

3 Way Distributor Valve

With Warning Light + Pressure Gauge

Main Dimensions



- ABCD73** – Fix up and down
- ABCD83** – with automatic return up and down
- ABCD93** – with automatic return up and fix down

(Dimensions in mm)

Main Data		
Working medium	Air	
Operating pressure (Bar)	up to 12	
Working temperature	Distributor valve	- 40 °C / + 80 °C
	Automatic fittings	- 20 °C / + 80 °C
Nominal diameter (mm)	4	
Weight (Kg)	0,4	

ABER is constantly engaged in improving its products and, therefore, reserves itself the right to modify without any further notice the characteristics shown